

J 1-180 Q10 NT22

Electric - Qmax 25 m³/h - 416 l/min (110 USgpm) - Hmax 53 m (174 ft)

Code: 8381064064



Indicative picture of the product

Product Data

Suction port	Threaded - 1 1/2" ISO 228 (BSP)
Delivery port	Threaded - 1 1/2" ISO 228 (BSP)
Qmax	25 m³/h - 416 l/min (110 USgpm)
Hmax	53 m (174 ft)
Solids handling	11 mm (0.4 ")
Motor power	7,5 kW - 10 HP
Motor type	IEC standard
	Winding for inverters
	Cast iron frame
Motor brand	WEG W22 Premium
Weight	120 kg

Close-coupled self-priming centrifugal pump with electric motor

Characteristics

The J series self-priming centrifugal pumps are used in applications where a rapid priming capacity is required from demanding suction heights combined with the ability to transfer and manage polluted fluids, dirty and abrasives with suspended large diameter solids. The system is based on an inspectable pump casing which also acts as a water tank allowing a first quick priming without auxiliary systems, simplifying management of the system and reducing the time for maintenance. Within the physically permitted suction height limits, J pumps are a more comfortable and reliable solution than submersible pumps and vertical submersed impeller pumps.

Benefits

- 1) Rapid self-priming**
Without foot valve up to a height of 7.5 m (24.5 ft)
- 2) High resistance**
To abrasive liquids which are turbid and sandy
- 3) Semi-open impeller**
High thickness casting impact resistant
- 4) Wear plate**
Easily replaceable cast iron wear plate, front to the impeller
- 5) Easy maintenance**
Removable front cover for direct access to the impeller

Applications

Industry:

clean, dirty, sandy, muddy, neutral, alkaline, acidic liquids; low viscous petroleum products, solvents even if dirty; milk of lime, caustic soda; washing, cooling, recirculation, smoke scrubbing.

Treatment:

pumping polluted corrosive wastewater containing sand, mud or solids in suspension; dosing neutralizing liquids; pumping out settled sludge.

Naval:

loading and unloading; bilge pumping; washing, fire-fighting, stripping, sanitary duty and circulation.

Agriculture:

surface irrigation; liquid manure oxygenation; transfer and spraying liquid manure or fertilizers; distribution of liquid animal feed; transfer of wine must; washing.

J 1-180 Q10 NT22

Performance Curves

Test according to **UNI EN ISO 9906 standard - level 2B**
 Test liquid: **clean water, density 1.000 kg/m³**
 Spherical solids handling: **D.11 mm (0.4 ")**

Priming time 3.450 rpm: **26s from 1,5 m (5 ft)**
 Installed power: **7,5 kW - 10 HP (3450 rpm)**

Noise curve

dB(A)=max noise level at 1 m

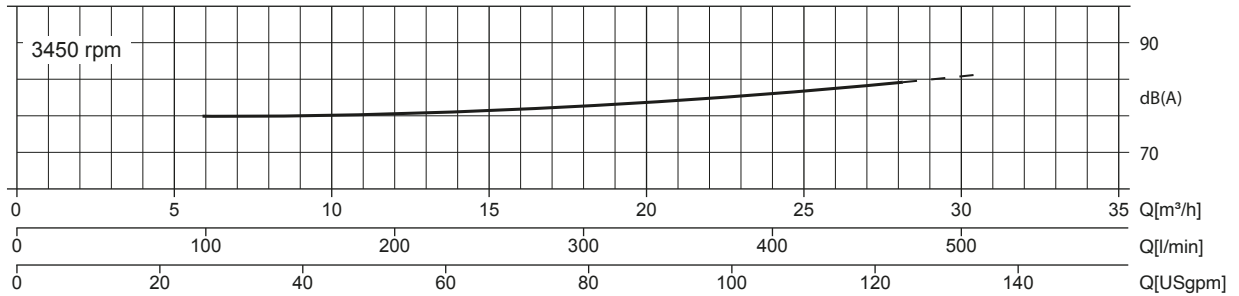

Multiple speed curve

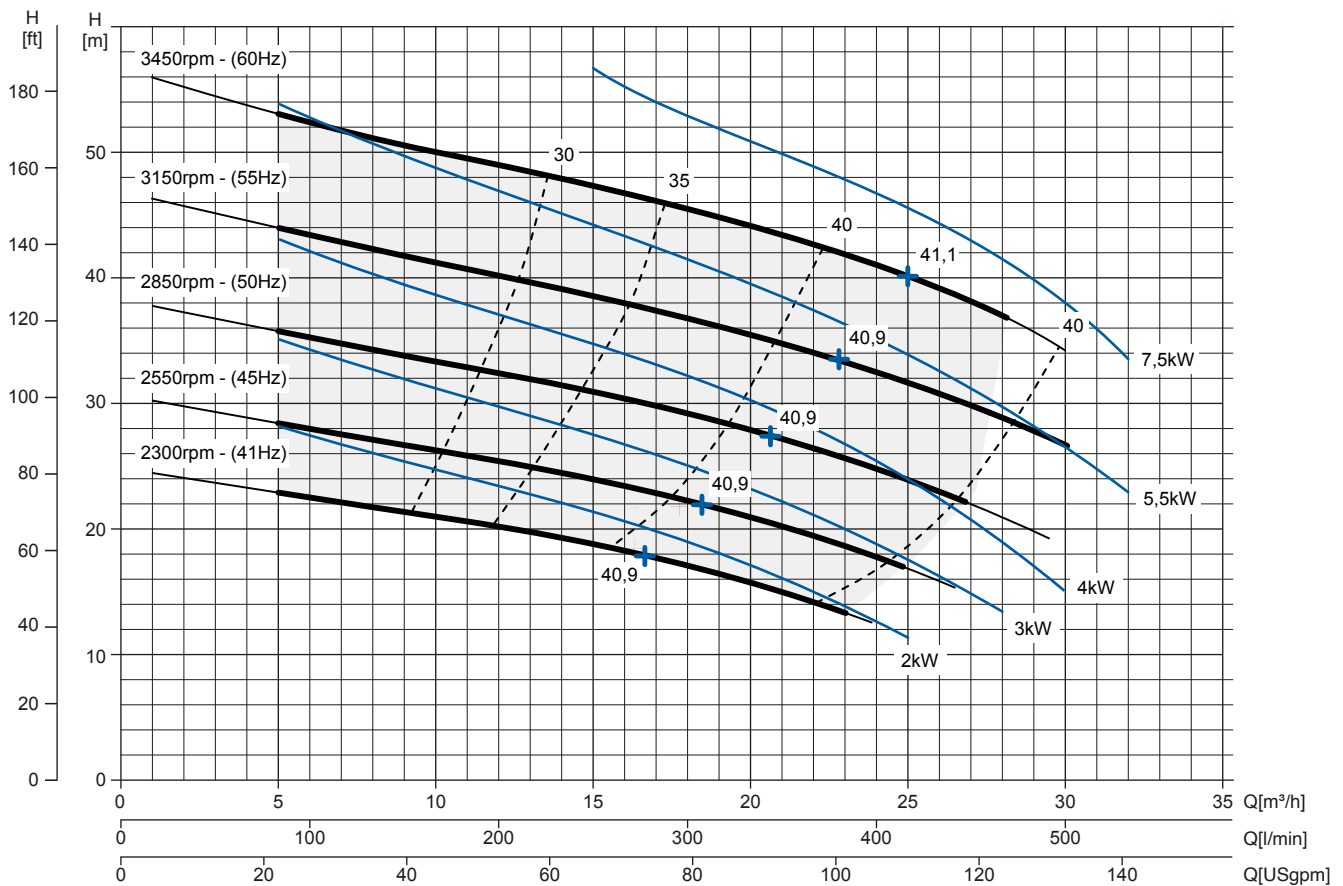

NPSHr Curve

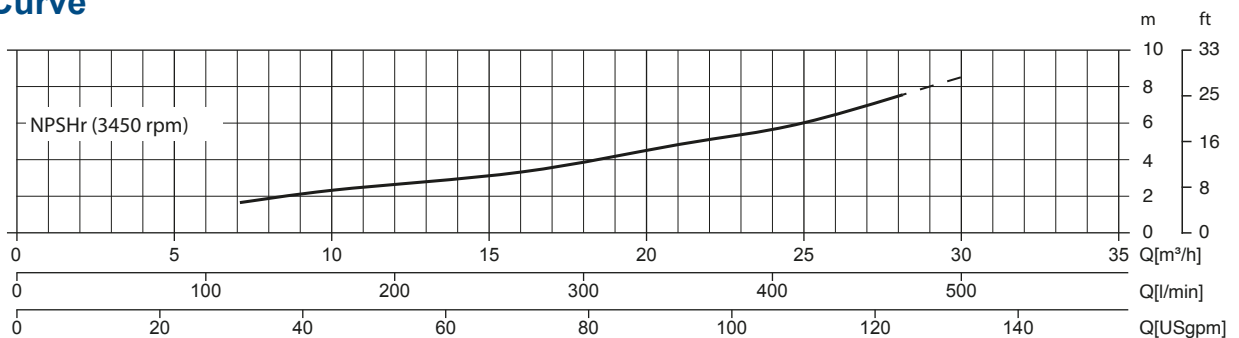

J 1-180 Q10 NT22

TECHNICAL DATA

Pump

Pump model	J 1-180 Q10
Qmax [3,450 rpm]	25 m ³ /h - 416 l/min (110 USgpm)
Hmax [3,450 rpm]	53 m (174 ft)
Suction port	Threaded - 1 1/2" ISO 228 (BSP)
Delivery port	Threaded - 1 1/2" ISO 228 (BSP)
Impeller type	Semi-open, 4 vanes
Solids handling	11 mm (0.4 ")
Casing	cast iron EN 1561 EN-GJL-200 + zinc anodes
Impeller	stainless steel inox ASTM A351 CF3M
Wear plate	stainless steel ASTM A351 CF3M
Non-return valve	Check-valve, FKM
Shaft	Stainless steel SAF 2205
Mechanical seal	Silicon carbide / Silicon carbide
Elastomers	FKM
Lubrication	Grease

Motor

Mains supply (Three-phase)	380 VD/660 VY ± 5%	400 VD/690 VY ± 10%	415 VD	460 VD/800 VY ± 10%	480 VD/830 VY ± 5%
Frequency (Nominal speed)	50 Hz ± 3% / 2.900 rpm			60 Hz ± 3% / 3.450 rpm	
Absorbed current	14,4/8,27 A	14,1/8,18 A	13,9/8,02 A	12,4/7,14 A	12,2/7,05 A
Starting Current Is/In	8	8.5	9	9.4	9.4
Efficiency (100%)	90,1% (IE3)	90,3% (IE3)	90,3% (IE3)	90,2% (IE3)	90,2% (IE3)
Model	WEG W22 Premium				
Standards	IEC 60034-1				
Construction	cast iron, TEFC				
Mounting arrangement	IM 2001 B35				
No. poles	2				
Rated power	7,5 kW - 10 HP				
Degree of protection	IP55				
Markings	CE, UL, CSA, EAC				
Insulation class/Temperature	F/80°K				
Duty type	Continuous - S1 Variable - suitable for inverter use (30-60 Hz)				
Temperature sensors	PTC, available as option				

Arrangement

Model	Close-coupled N
Dimensions	360 x 775 x 428 mm (14 x 30 x 16")
Painting	Polyurethan enamel, average thickness of 100 µm
Color	RAL 5010 blue (standard)
Features	Close-coupled with rigid coupling "N"
Height connection	0.2 m (10")

Options

Flanged ports DN40 PN16 EN1092-1 Type B	cod. 10042789
Flanged ports 1 1/2" ANSI B16.1 Class 125 R.F.	cod. 10042825
Automatic mechanical seal greaser	cod. 10008316
Integrated VSD motor inverter	Available by 2021

Weight

Net weight	120 kg
------------	--------

J 1-180 Q10 NT22

DIMENSIONS

mm [in]

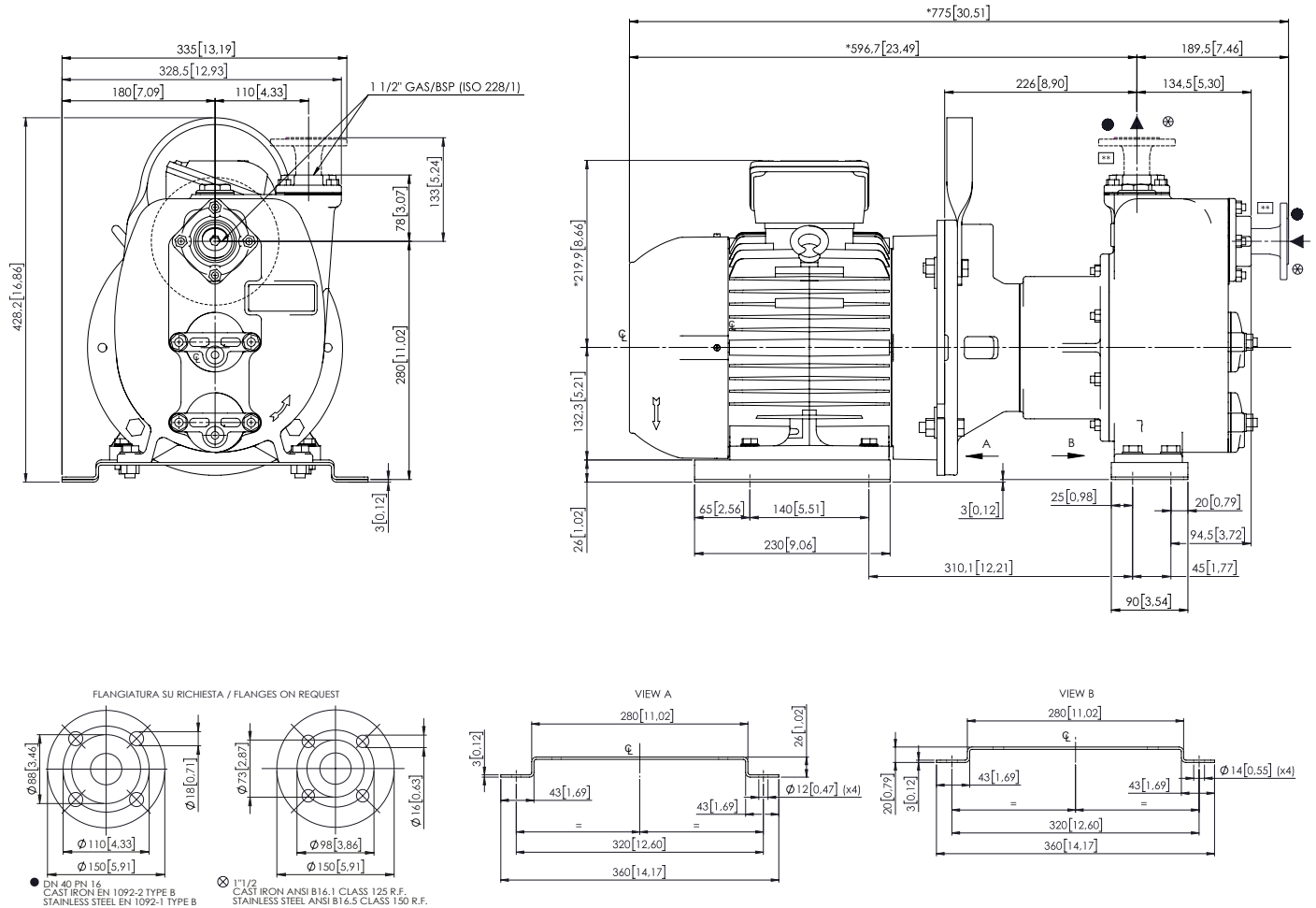

PACKAGING DIMENSIONS

Dimensions

J 1-180 Q10 NT22 (L x W x H mm)

720 x 270 x 480 + BOX

Gross weight (pump + packing)

127 kg

